

# Clutch Roller Shade Sections - R8 Open Roll

## Shade Tube



### Tube Specifications:

- Aluminum, Mill Finish
- Double Sided Super Strength Adhesive

## Fabric to Tube Adhesion

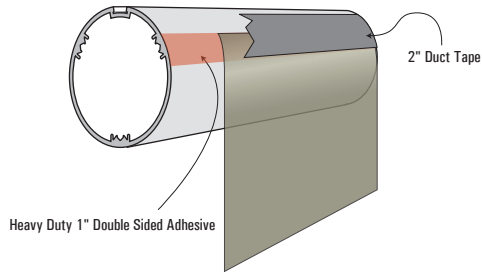

### Adhesion Specifications:

- Apply fabric panel to tube using double sided adhesive
- Apply 2" duct tape as an over tape protection
- Roll fabric 2x around tube before counting length

## Shade Mounting

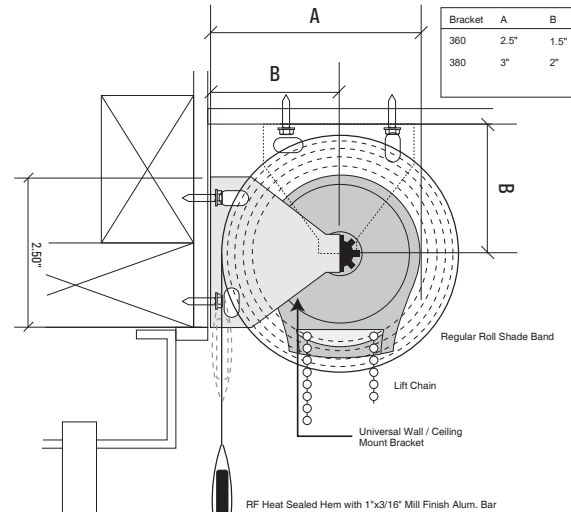

## Hem Pocket

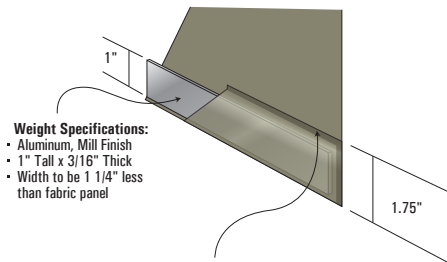

### Weight Specifications:

- Aluminum, Mill Finish
- 1" Tall x 3/16" Thick
- Width to be 1 1/4" less than fabric panel

### Weld Specifications:

- All 3 Sides to fully conceal Weight Bar
- RF Weld to be 1/4" foot print providing secure adhesion

## Clutch System

### R8 Rollease Clutch

25 Yr  
Warranty

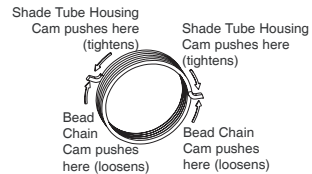
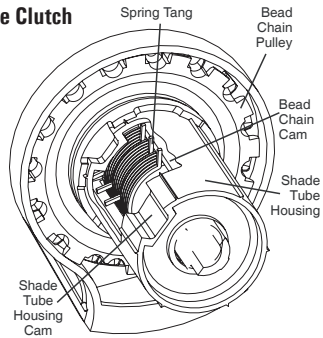

### Clutch Specs:

- No Adjustments are ever required
- Rated to lift 16 lbs

### Rollease Idler End Parts

#### Idler End Bracket with Retainer

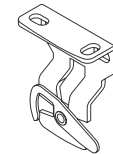

#### Idler End Plug

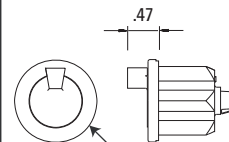

Flange diameter matches outside diameter of tube



# Clutch Roller Shade Sections - R8/3" Fascia

## Shade Tube



### Tube Specifications:

- Aluminum, Mill Finish
- Double Sided Super Strength Adhesive

## Fabric to Tube Adhesion

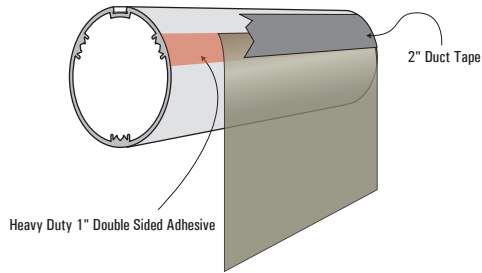

### Adhesion Specifications:

- Apply fabric panel to tube using double sided adhesive
- Apply 2" duct tape as an over tape protection
- Roll fabric 2x around tube before counting length

## Shade Mounting

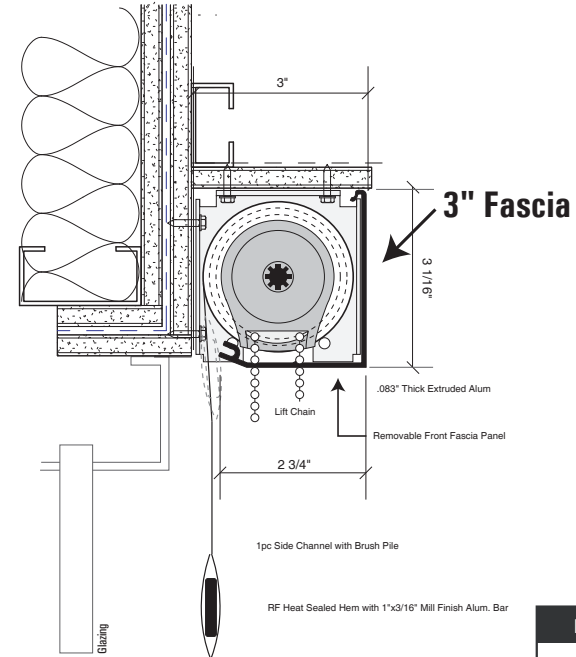

## Hem Pocket

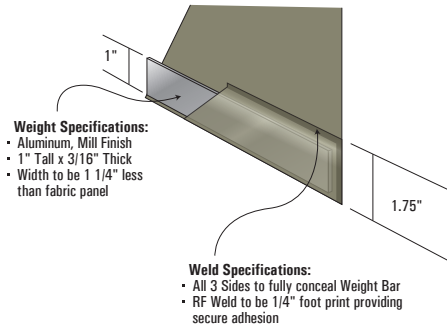

### Weight Specifications:

- Aluminum, Mill Finish
- 1" Tall x 3/16" Thick
- Width to be 1 1/4" less than fabric panel

### Weld Specifications:

- All 3 Sides to fully conceal Weight Bar
- RF Weld to be 1/4" foot print providing secure adhesion

## Clutch System

### R8 Rollease Clutch

25 Yr  
Warranty

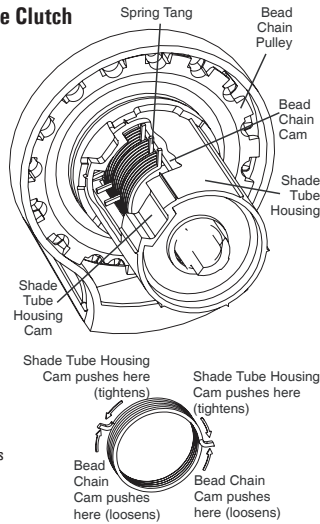

### Clutch Specs:

- No Adjustments are ever required
- Rated to lift 16 lbs

### Rollease Idler End Parts

#### Idler End Bracket with Retainer

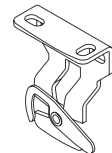

#### Idler End Plug

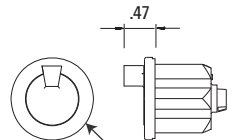

# Clutch Roller Shade Sections - R8/4" Fascia

## Shade Tube



### Tube Specifications:

- Aluminum, Mill Finish
- Double Sided Super Strength Adhesive

## Fabric to Tube Adhesion

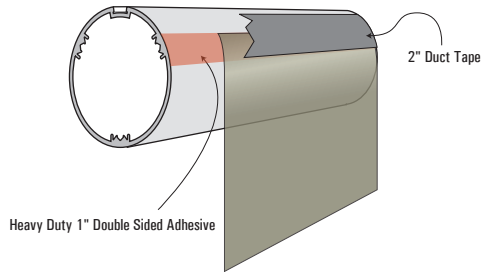

### Adhesion Specifications:

- Apply fabric panel to tube using double sided adhesive
- Apply 2" duct tape as an over tape protection
- Roll fabric 2x around tube before counting length

## Shade Mounting

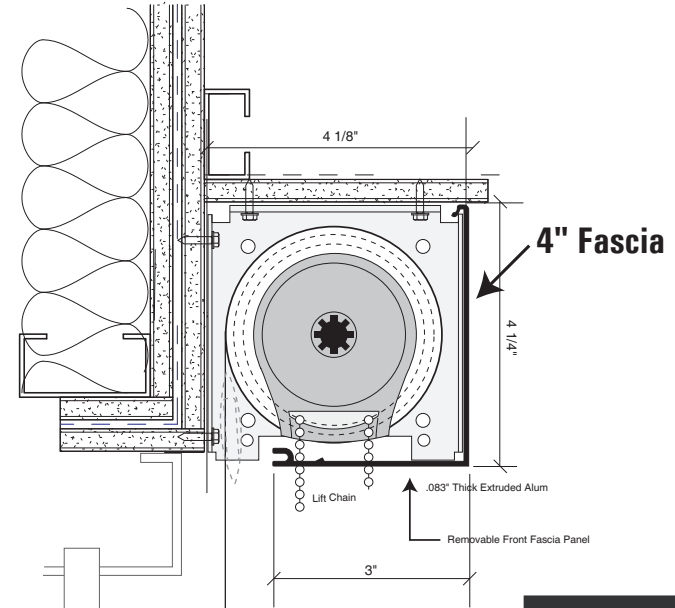

## Hem Pocket

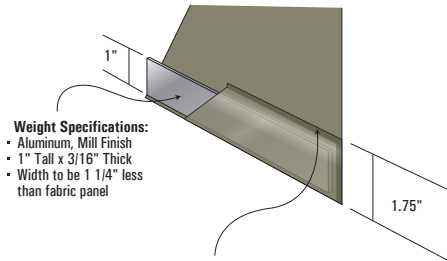

### Weight Specifications:

- Aluminum, Mill Finish
- 1" Tall x 3/16" Thick
- Width to be 1 1/4" less than fabric panel

### Weld Specifications:

- All 3 Sides to fully conceal Weight Bar
- RF Weld to be 1/4" foot print providing secure adhesion

## Clutch System

### R8 Rollease Clutch

**25 Yr**  
Warranty

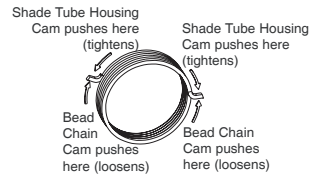
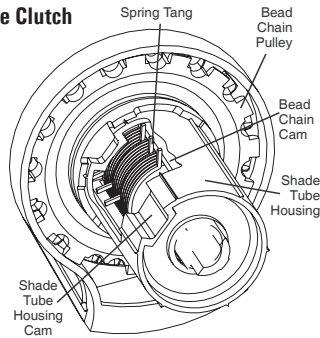

### Clutch Specs:

- No Adjustments are ever required
- Rated to lift 16 lbs

### Rollease Idler End Parts

#### Idler End Bracket with Retainer

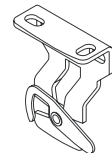

#### Idler End Plug

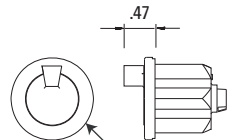

Flange diameter matches outside diameter of tube



# Clutch Roller Shade Sections - R8/4" Dual Shade Fascia

## Shade Tube



- Tube Specifications:
- Aluminum, Mill Finish
  - Double Sided Super Strength Adhesive

## Fabric to Tube Adhesion

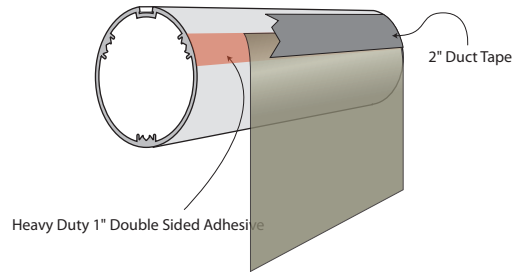

- Adhesion Specifications:
- Apply fabric panel to tube using double sided adhesive
  - Apply 2" duct tape as an over tape protection
  - Roll fabric 2x around tube before counting length

## Shade Mounting

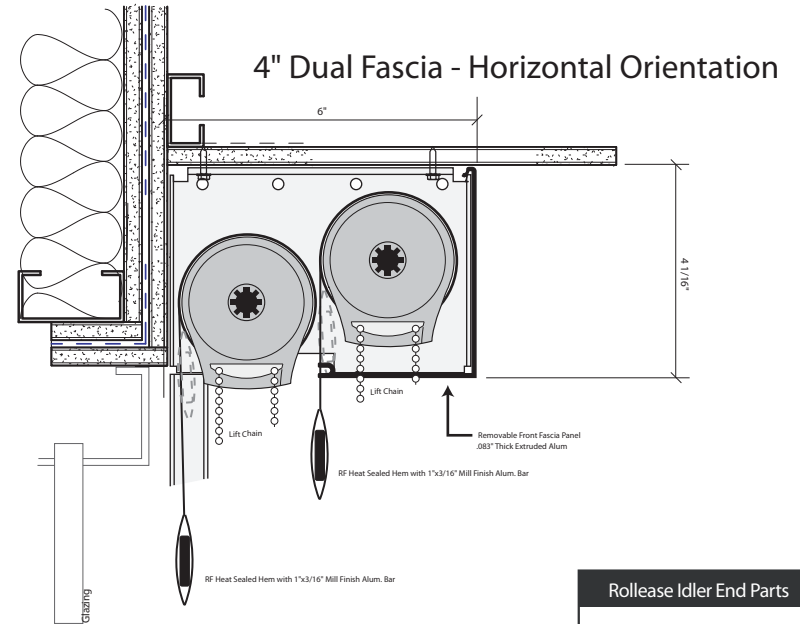

## Hem Pocket

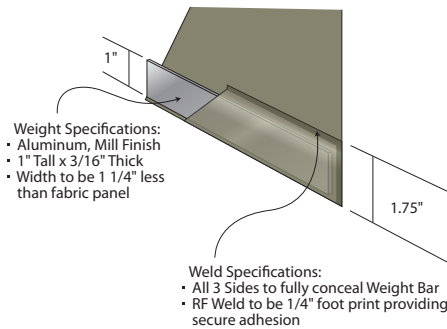

## Clutch System

### R8 Rollease Clutch

25 Yr  
Warranty

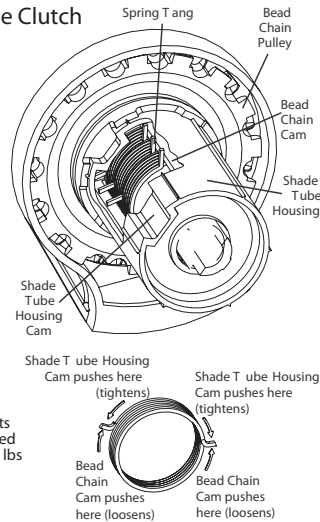

- Clutch Specs:
- No Adjustments are ever required
  - Rated to lift 16 lbs

### Rollease Idler End Parts

#### Idler End Bracket with Retainer

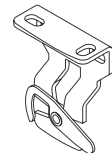

#### Idler End Plug

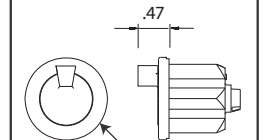

# Clutch Roller Shade Sections - R16+ Open Roll

## Shade Tube



### Tube Specifications:

- Aluminum, Mill Finish
- Double Sided Super Strength Adhesive

## Fabric to Tube Adhesion

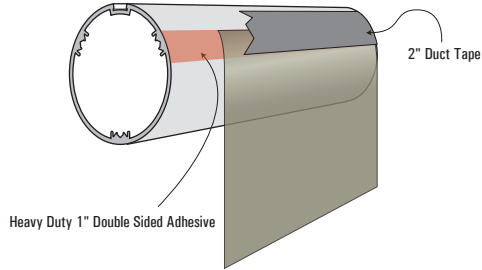

### Adhesion Specifications:

- Apply fabric panel to tube using double sided adhesive
- Apply 2" duct tape as an over tape protection
- Roll fabric 2x around tube before counting length

## Shade Mounting

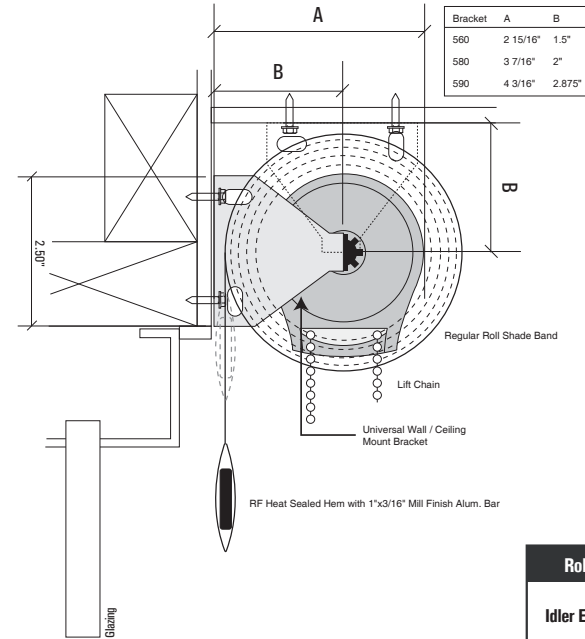

## Hem Pocket

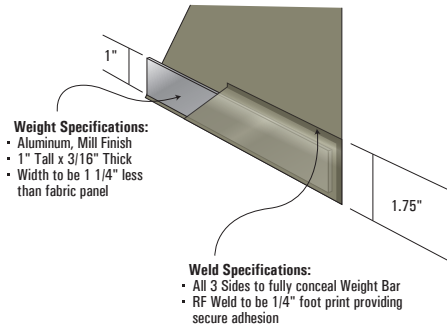

## Clutch System

### R16 Rollease Clutch

**25 Yr**  
Warranty

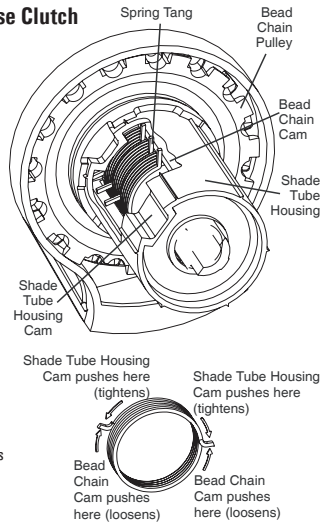

- Clutch Specs:**
- No Adjustments are ever required
  - Rated to lift 16 lbs

### Rollease Idler End Parts

#### Idler End Bracket with Retainer

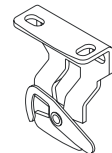

#### Idler End Plug

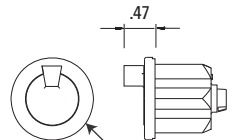

Flange diameter matches outside diameter of tube



# Clutch Roller Shade Sections - R16+/3" Fascia,

## Shade Tube



### Tube Specifications:

- Cold rolled painted steel construction
- Double Sided Super Strength Adhesive

## Fabric to Tube Adhesion

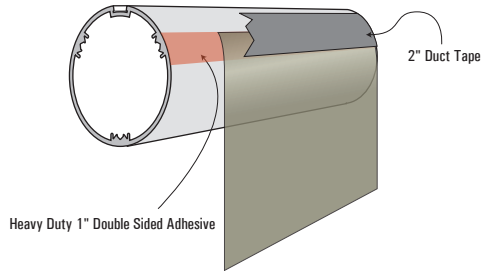

### Adhesion Specifications:

- Apply fabric panel to tube using double sided adhesive
- Apply 2" duct tape as an over tape protection
- Roll fabric 2x around tube before counting length

## Shade Mounting

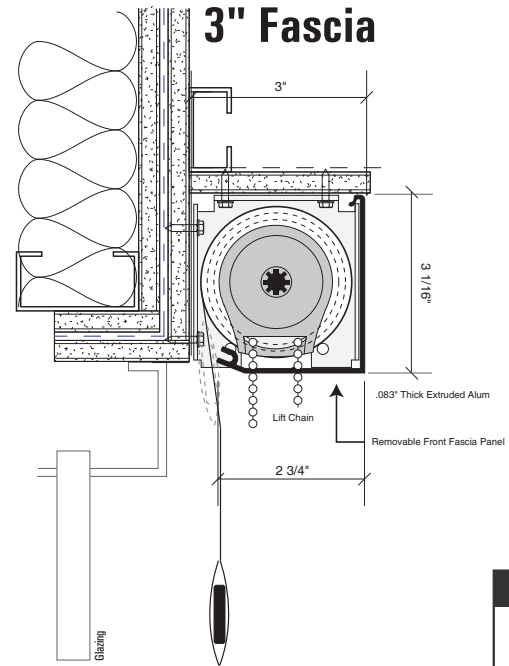

## Hem Pocket

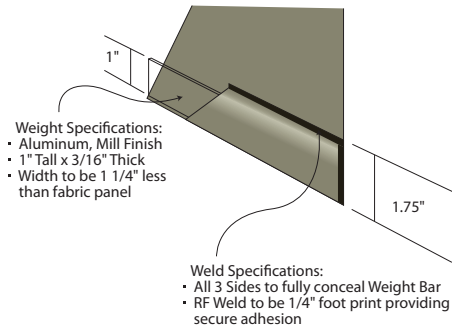

## Clutch System

### R16 Rollease Clutch

**25 Yr**  
Warranty

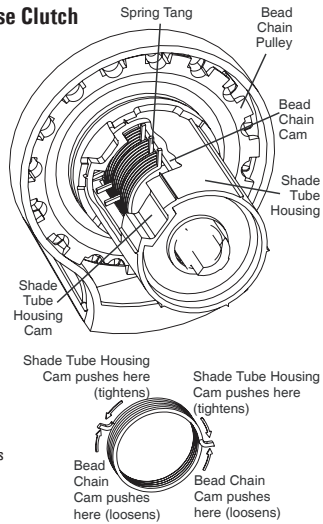

- Clutch Specs:**
- No Adjustments are ever required
  - Rated to lift 16 lbs

### Rollease Idler End Parts

#### Idler End Bracket with Retainer

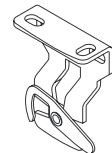

#### Idler End Plug

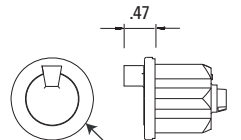

Flange diameter matches outside diameter of tube



# Clutch Roller Shade Sections - R16+/3" Fascia, Top Back

## Shade Tube



### Tube Specifications:

- Cold rolled painted steel construction
- Double Sided Super Strength Adhesive

## Fabric to Tube Adhesion

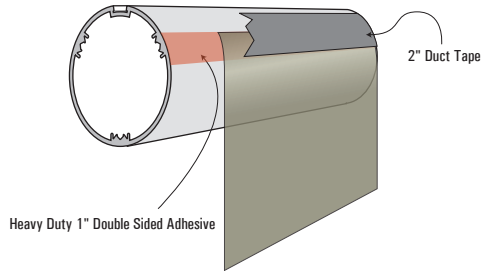

### Adhesion Specifications:

- Apply fabric panel to tube using double sided adhesive
- Apply 2" duct tape as an over tape protection
- Roll fabric 2x around tube before counting length

## Shade Mounting

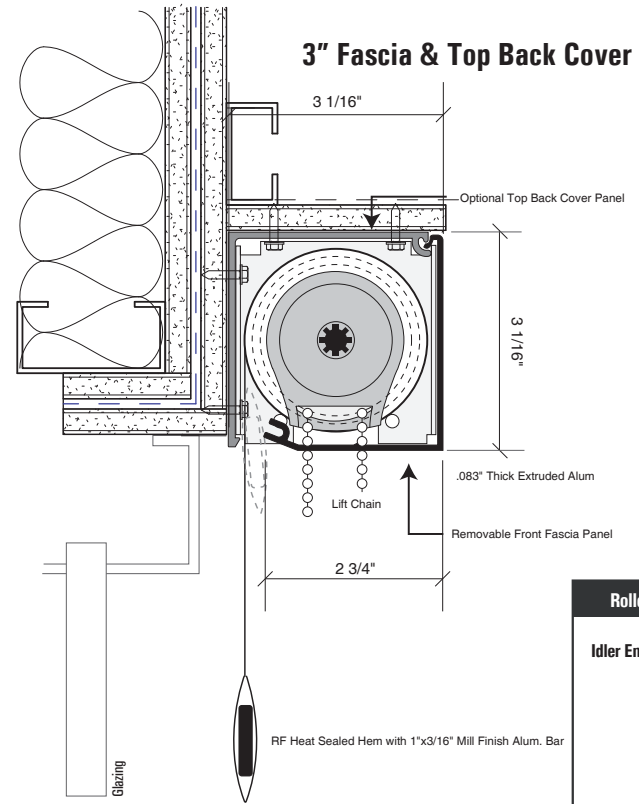

## Hem Pocket

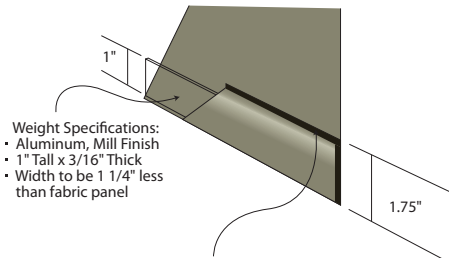

### Weight Specifications:

- Aluminum, Mill Finish
- 1" Tall x 3/16" Thick
- Width to be 1 1/4" less than fabric panel

### Weld Specifications:

- All 3 Sides to fully conceal Weight Bar
- RF Weld to be 1/4" foot print providing secure adhesion

## Clutch System

### R16 Rollease Clutch

25 Yr  
Warranty

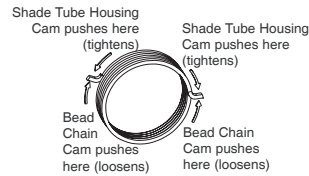
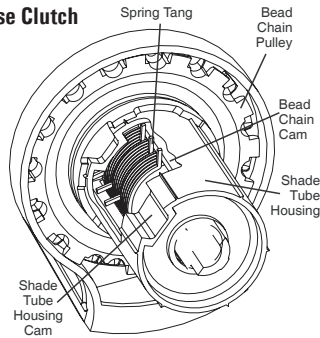

### Clutch Specs:

- No Adjustments are ever required
- Rated to lift 16 lbs

### Rollease Idler End Parts

#### Idler End Bracket with Retainer

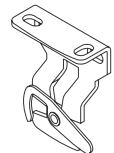

#### Idler End Plug

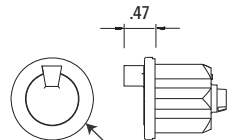

Flange diameter matches outside diameter of tube



# Clutch Roller Shade Sections - R16+/4" Fascia

## Shade Tube



### Tube Specifications:

- Aluminum, Mill Finish
- Double Sided Super Strength Adhesive

## Fabric to Tube Adhesion

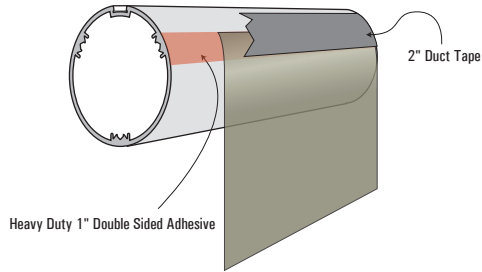

### Adhesion Specifications:

- Apply fabric panel to tube using double sided adhesive
- Apply 2" duct tape as an over tape protection
- Roll fabric 2x around tube before counting length

## Shade Mounting

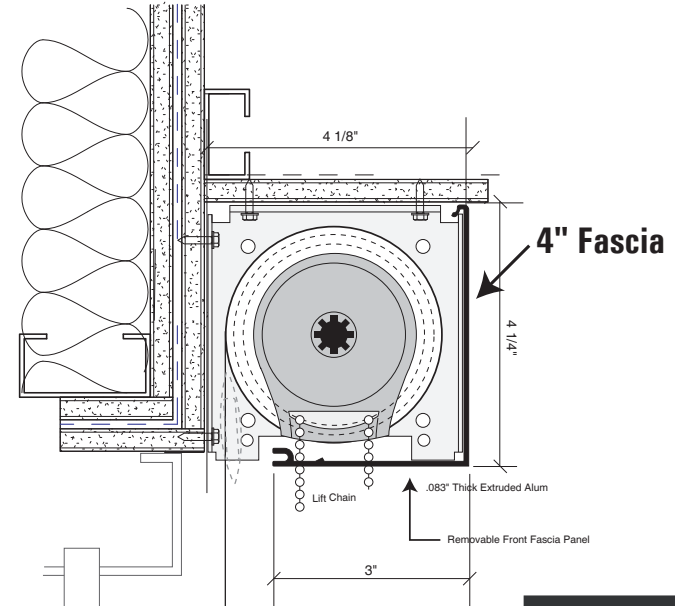

## Hem Pocket

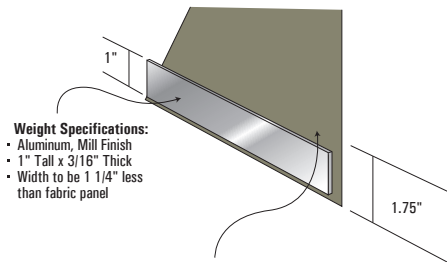

### Weight Specifications:

- Aluminum, Mill Finish
- 1" Tall x 3/16" Thick
- Width to be 1 1/4" less than fabric panel

### Weld Specifications:

- All 3 Sides to fully conceal Weight Bar
- RF Weld to be 1/4" foot print providing secure adhesion

## Clutch System

### R16 Rollease Clutch

25 Yr  
Warranty

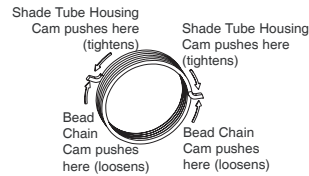
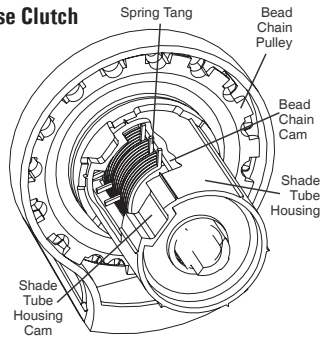

- ### Clutch Specs:
- No Adjustments are ever required
  - Rated to lift 16 lbs

### Rollease Idler End Parts

#### Idler End Bracket with Retainer

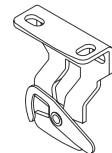

#### Idler End Plug

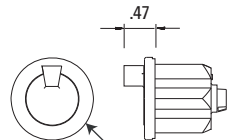

Flange diameter matches outside diameter of tube





# Clutch Roller Shade Sections - R16+/4" Fascia, Top Back, Side Channels, Sill Angle

## Shade Tube



### Tube Specifications:

- Aluminum, Mill Finish
- Double Sided Super Strength Adhesive

## Fabric to Tube Adhesion

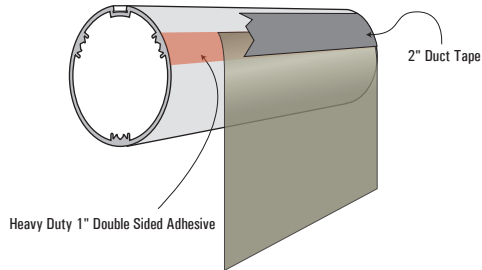

### Adhesion Specifications:

- Apply fabric panel to tube using double sided adhesive
- Apply 2" duct tape as an over tape protection
- Roll fabric 2x around tube before counting length

## Shade Mounting

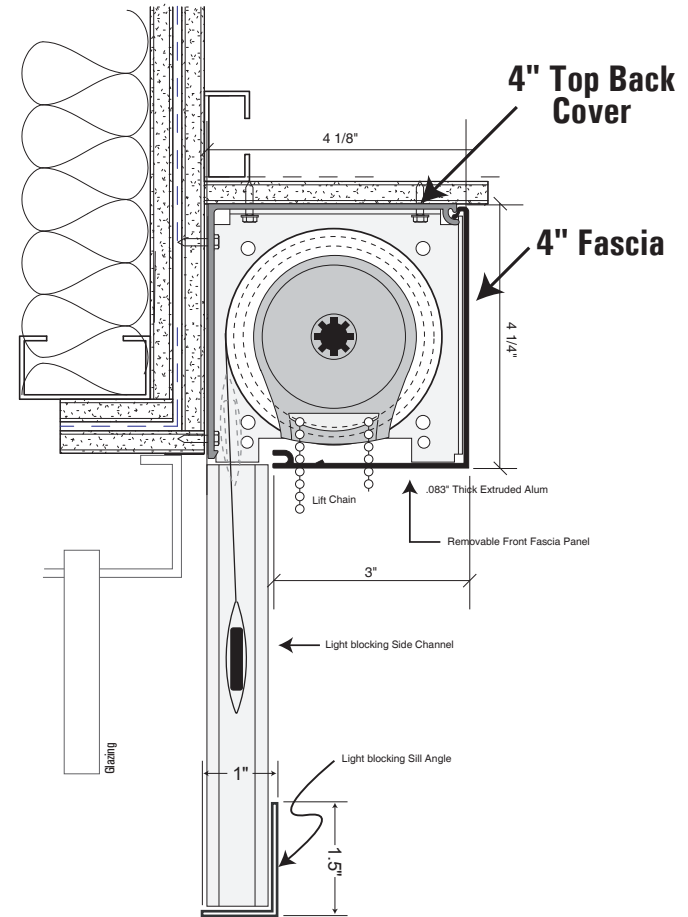

## Hem Bar

**Slim Architectural Exposed**

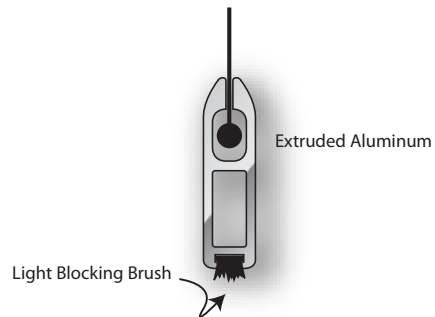

## Clutch System

### R16 Rollease Clutch

**25 Yr Warranty**

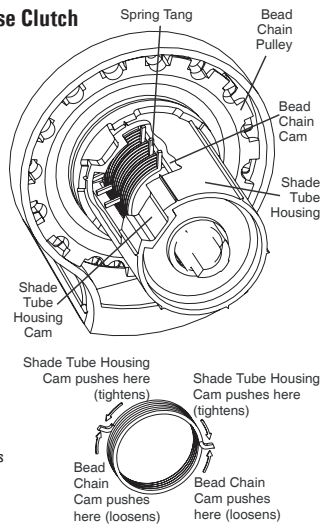

### Clutch Specs:

- No Adjustments are ever required
- Rated to lift 16 lbs



# Clutch Roller Shade Sections - R16/7" Fascia, Side Channels

## Shade Tube



### Tube Specifications:

- Aluminum, Mill Finish
- Double Sided Super Strength Adhesive

## Fabric to Tube Adhesion

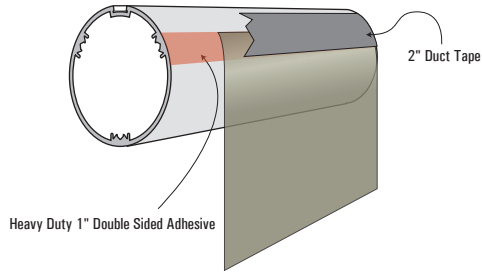

### Adhesion Specifications:

- Apply fabric panel to tube using double sided adhesive
- Apply 2" duct tape as an over tape protection
- Roll fabric 2x around tube before counting length

## Shade Mounting

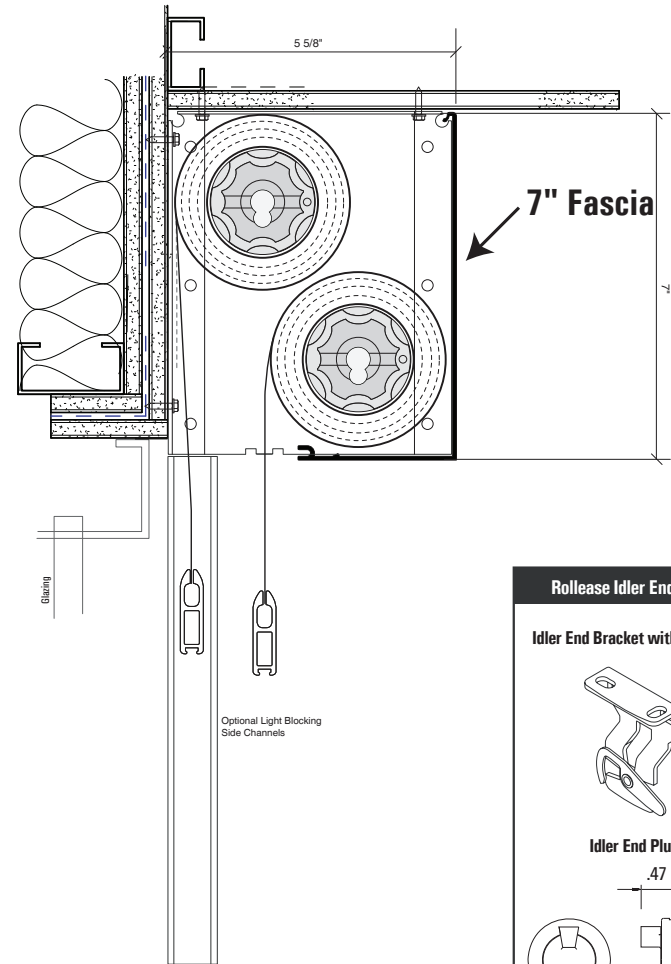

## Hem Style

### Slim Architectural Exposed

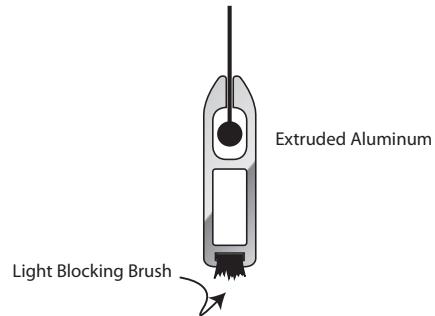

## Clutch System

### R16 Rollease Clutch

25 Yr  
Warranty

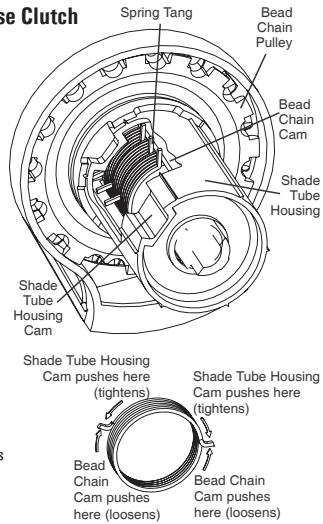

- ### Clutch Specs:
- No Adjustments are ever required
  - Rated to lift 16 lbs

### Rollease Idler End Parts

#### Idler End Bracket with Retainer

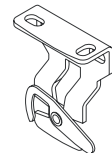

#### Idler End Plug

